

ORDER DETAILS	
MOCKUP NO.	WUFOO.
INQUIRY NO.	INQUIRY..V1
ORDER NO.	
PRODUCT DETAILS	
SIZE	KING SLIM SIZE (KSS - TIPS - ELASTIC - ENC)
PAPER TYPE	
QUANTITY	
BOX PACKING	22 BOOKLETS A BOX
VALUE ADDITION	
PRINTING EFFECT	CMYK

\_\_\_\_\_ DIE CUT LINE  
 - - - - - FOLD LINE  
 - - - - - BLEED LINE

**REMARKS:**  
 - Artwork should be submitted in AI, EPS, PDF, CDR, PSD.  
 - For JPEG, PNG and PSD please submit your artwork with a minimum of 300dpi

Please see the text and graphic direction guideline below.

I accept the artwork and understand that any mistakes or omissions is my responsibility.  
 DATE: .....  
 PRINT NAME: .....  
 APPROVAL SIGNATURE: .....

**OUTSIDE**

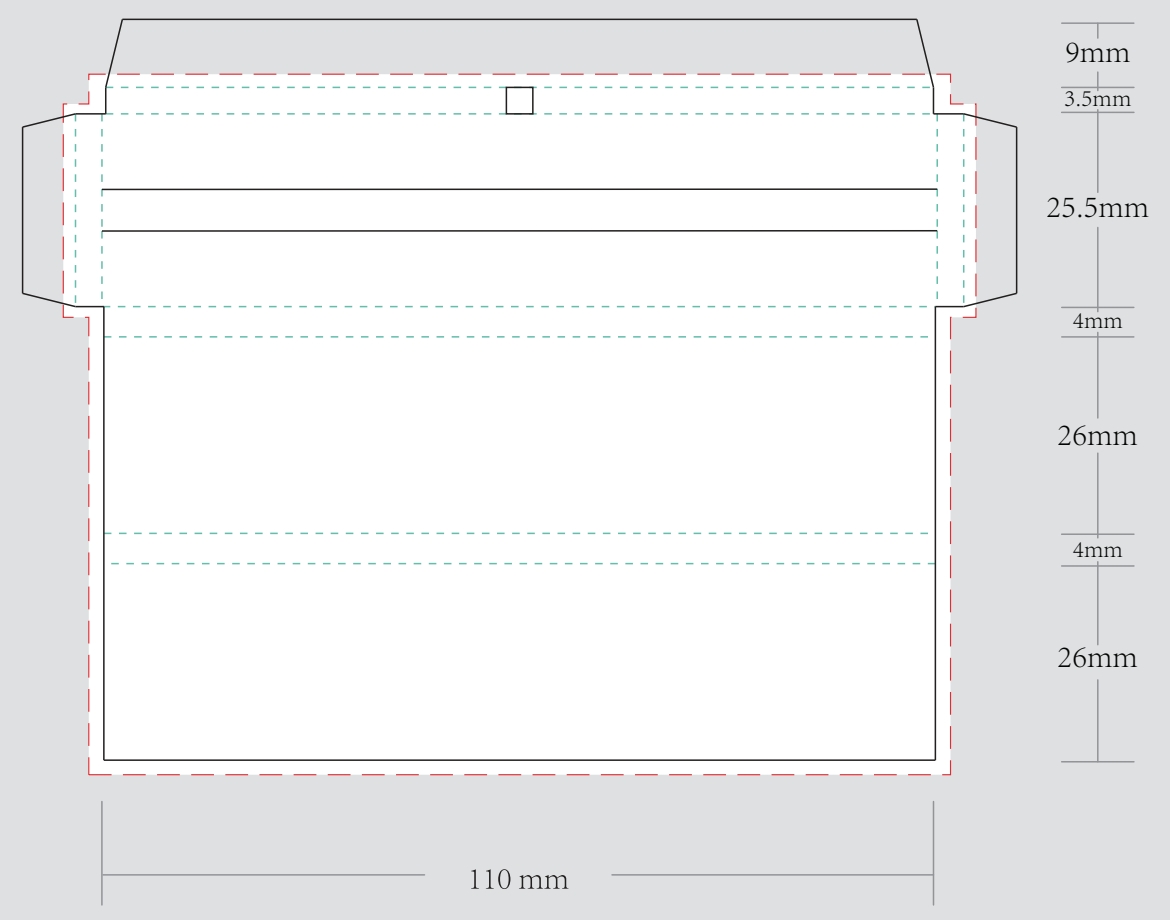

**INSIDE**

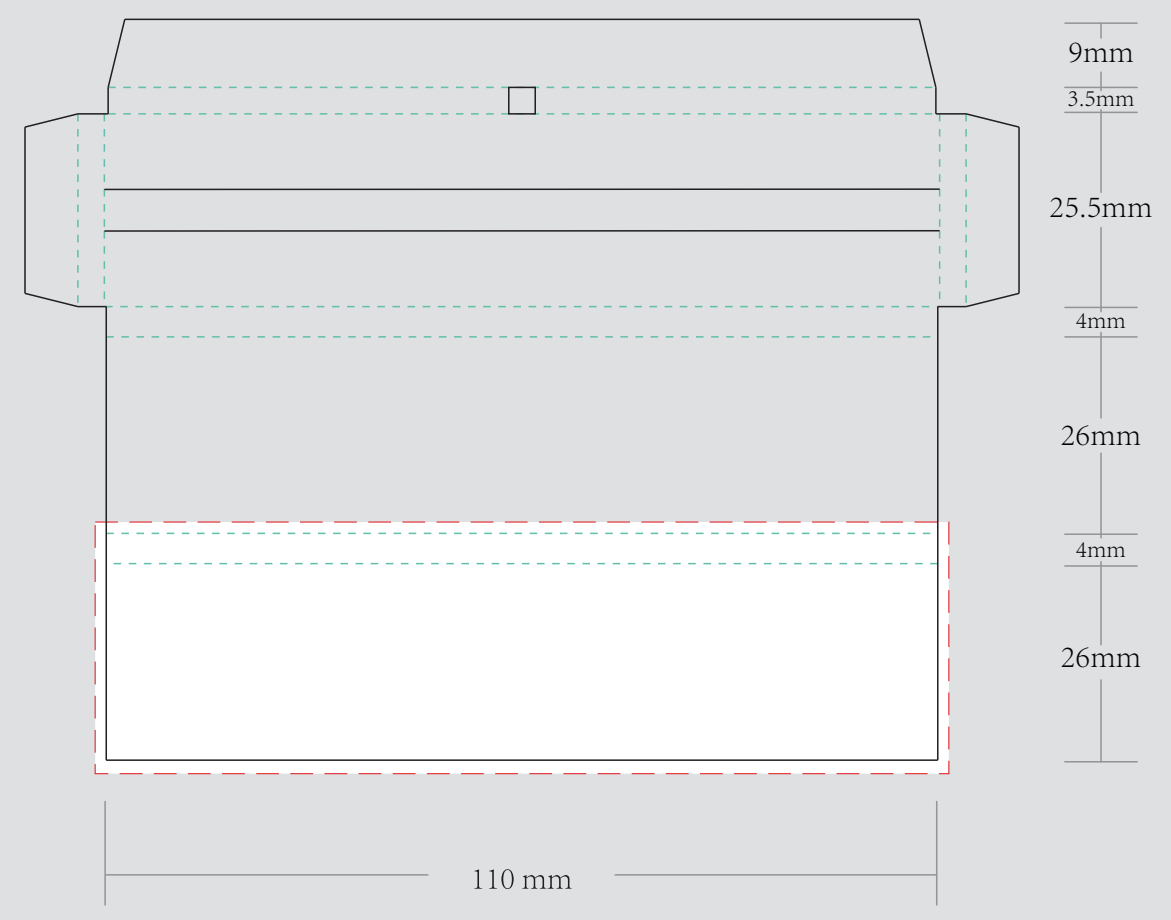

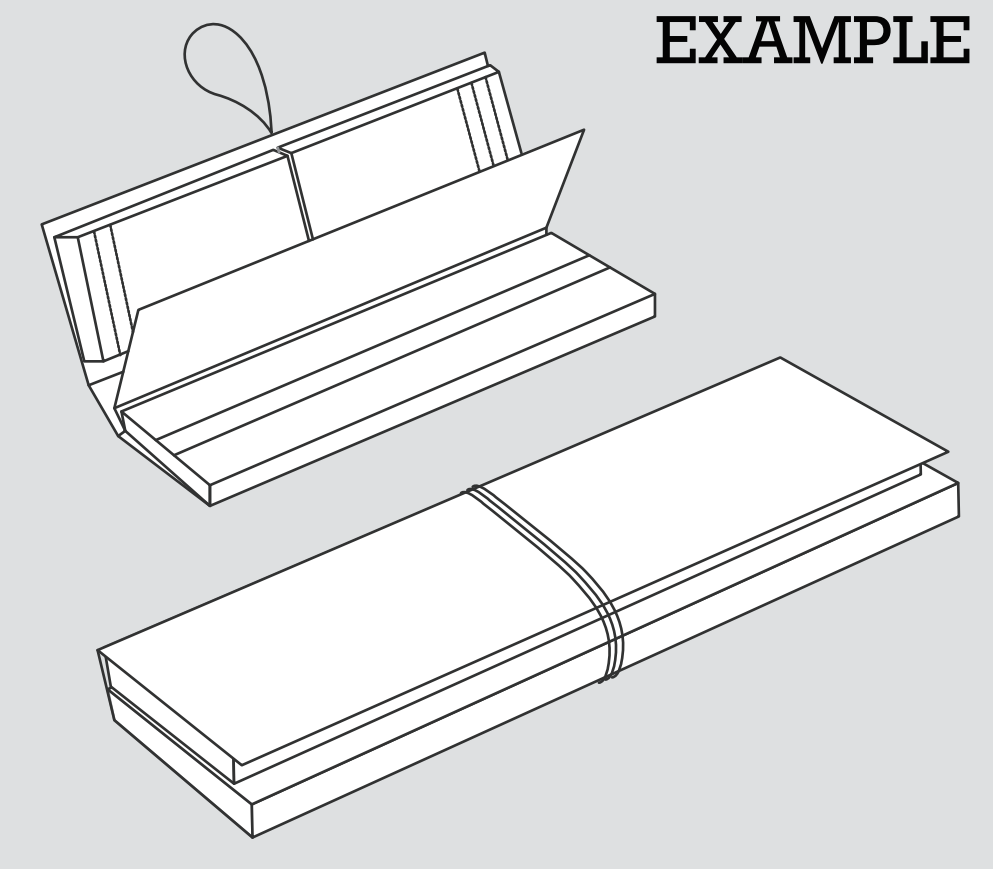

**EXAMPLE**

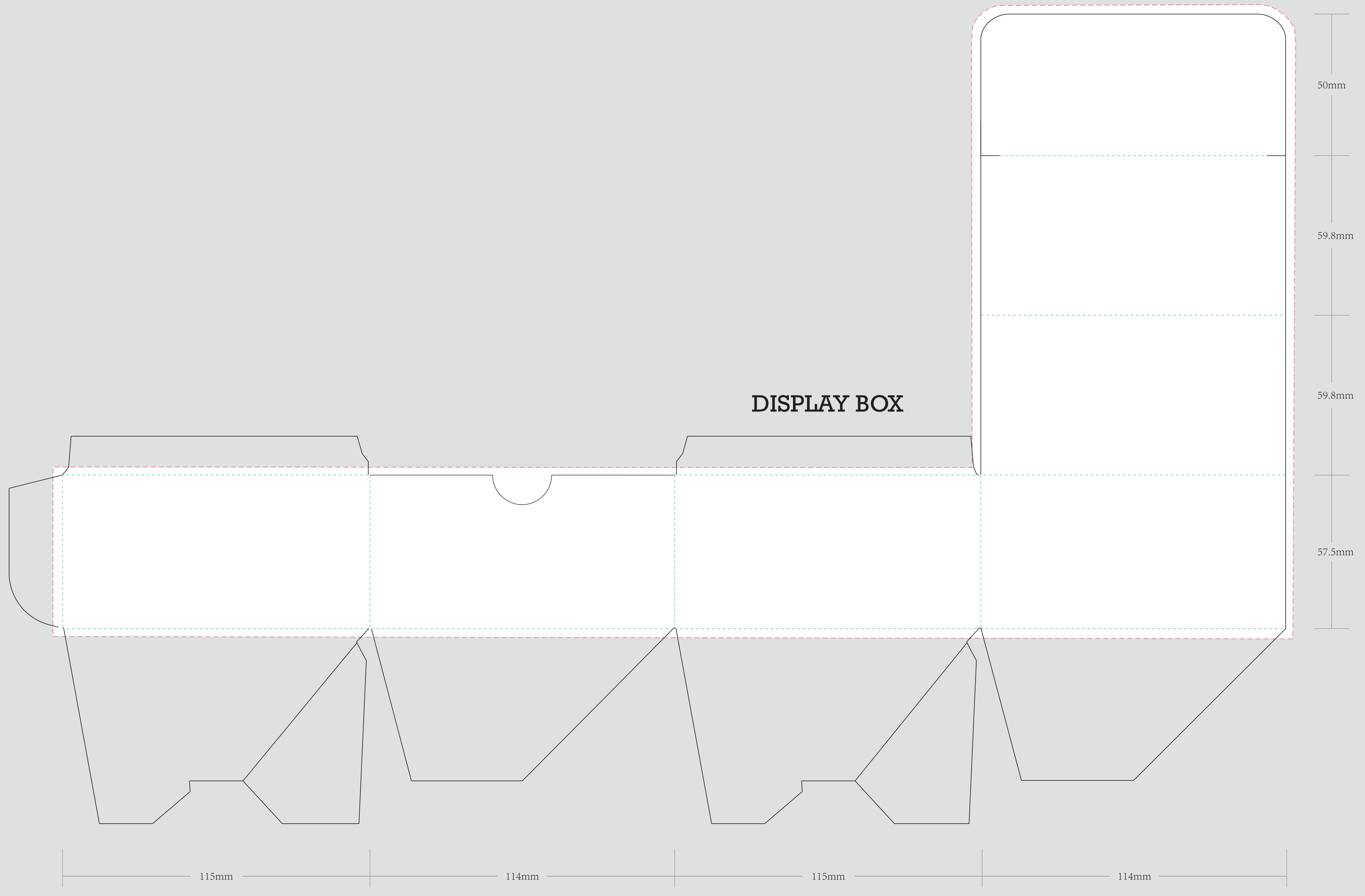

**DISPLAY BOX**



ORDER DETAILS	
MOCKUP NO.	WUFOO.
INQUIRY NO.	INQUIRY..V1
ORDER NO.	
PRODUCT DETAILS	
SIZE	KING SLIM SIZE (KSS - TIPS - ELASTIC - ENC)
PAPER TYPE	
QUANTITY	
BOX PACKING	22 BOOKLETS A BOX
VALUE ADDITION	
PRINTING EFFECT	CMYK

 **DIE CUT LINE**  
 **FOLD LINE**  
 **BLEED LINE**

**REMARKS:**  
 - Artwork should be submitted in AI, EPS, PDF, CDR, PSD.  
 - For JPEG, PNG and PSD please submit your artwork with a minimum of 300dpi

Please see the text and graphic direction guideline below.

VISIBLE AREA

BACK  

---

 POSSIBLE TEXT & GRAPHICS  

---

 FRONT

BOOKLETS AREA  

---

 POSSIBLE TEXT & GRAPHICS  

---

 TIPS AREA

I accept the artwork and understand that any mistakes or omissions is my responsibility.

DATE: .....

PRINT NAME: .....

APPROVAL SIGNATURE: .....

## OUTSIDE



## INSIDE

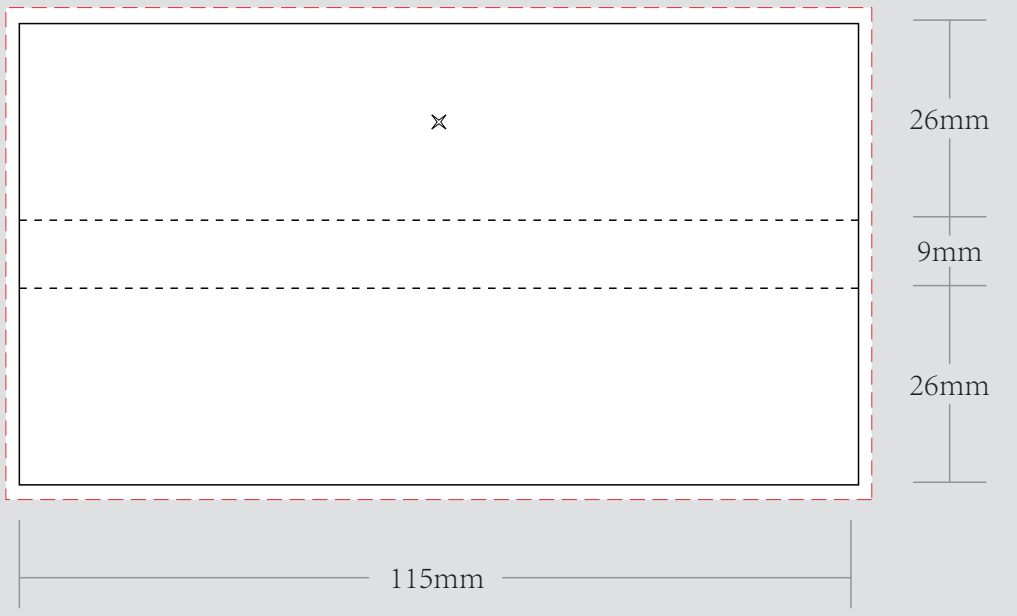

## EXAMPLE

